

SMART Board VariHite

Configuration & User Manual for Mobile Stand

Note: To be used in conjunction with the manual for the appropriate accessory

Please also refer to Advisory Note, Doc. Ref 33-062-A

Part No. 140000

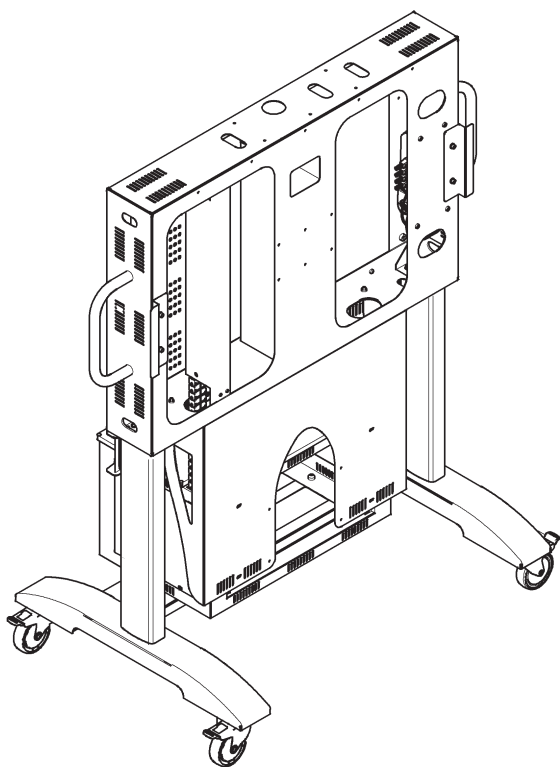

FRONT AND SIDE VIEW

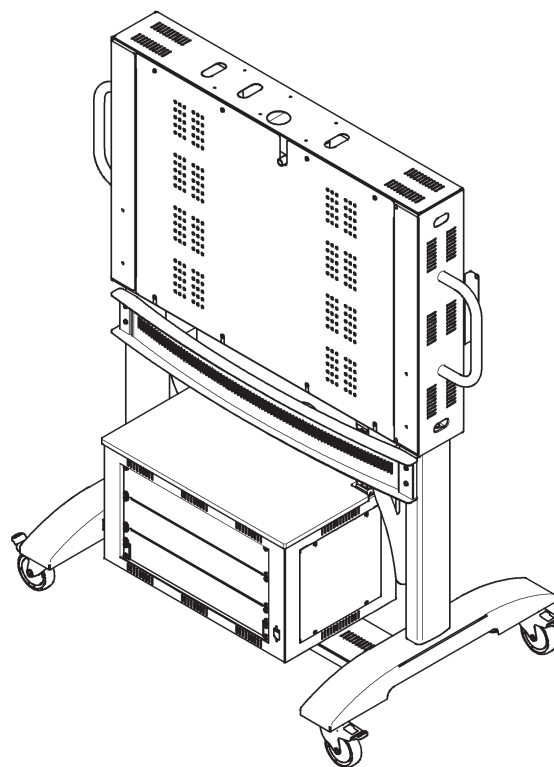

REAR AND SIDE VIEW

SMART Board VariHite

Physical Specifications

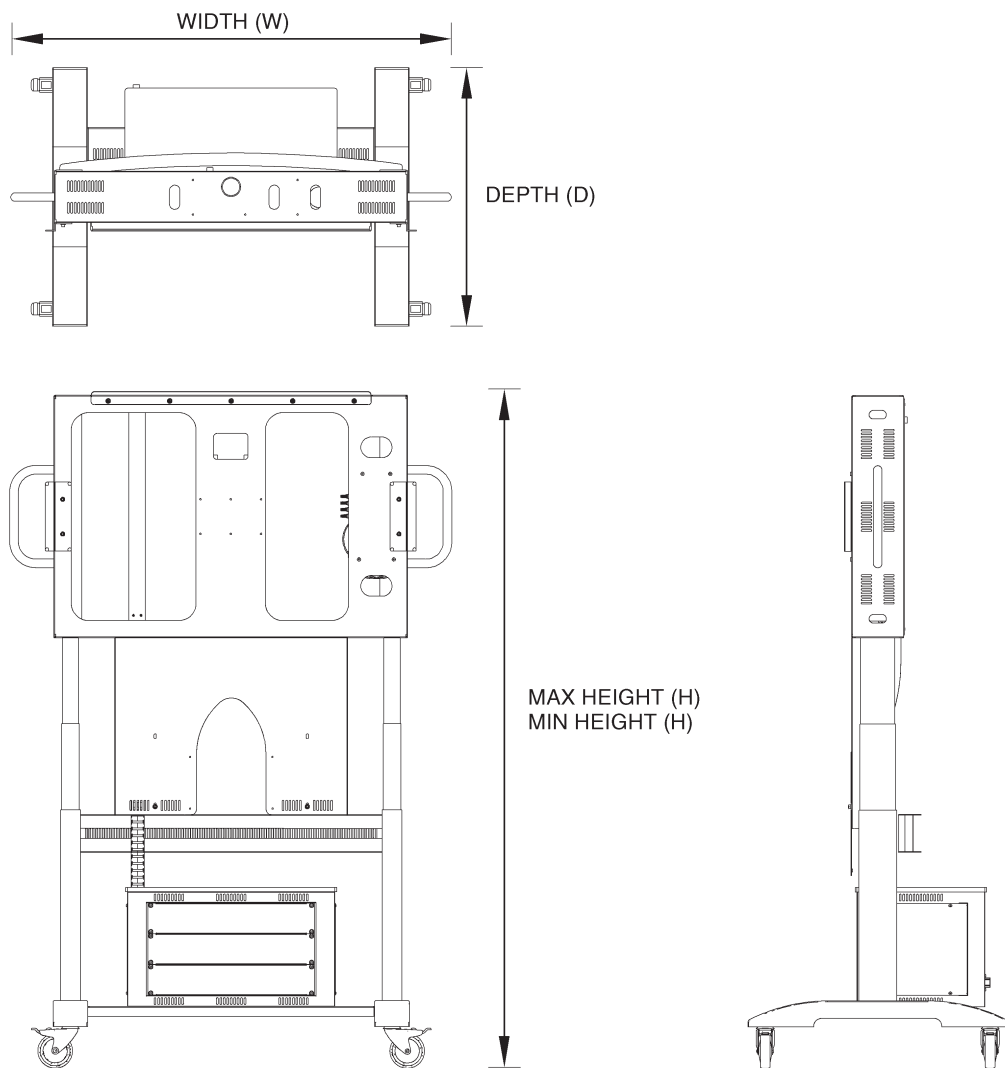

Size	TeamMate VariHite Mobile Stand Only 1270mm (W) x 1470mm (H) min - 1950mm (H) max x 750mm (D)
	TeamMate VariHite 6U rack unit only 440mm (W) x 126mm (H) x 135mm (D)
Weight	Stand only 80 kg Supported SMART Board systems: 685ix - 660i - 680i - 685i - 6052i
Shipping Size	1 Unit on Pallet (included) 1400mm (W) x 1700mm (H) x 930mm (D) Shipping Weight 95kg

Note: dimensions ± 3mm. All weights ± 0.9kg

SMART Board VariHite

Safety warnings, cautions and important information

Before you install and use the SMART Board interactive whiteboard system to the TeamMate VariHite Mobile Stand, please read, understand and observe the Safety Warnings, Cautions, Important Information and Assembly Instructions in this User Manual. The manual describes the safe and correct operation of the TeamMate VariHite Stand, helping you to prevent injuries and equipment damage. You should always ensure that the TeamMate VariHite Mobile Stand is being used correctly.

If you own a TeamMate product other than a TeamMate VariHite for SMART Board Mobile Stand system, please refer to the Installation Guide or User Manual that came with your product for relevant warnings and maintenance instructions.

The TeamMate VariHite Stand is designed to work with certain SMART Board interactive models only. The TeamMate VariHite Stand for SMART Board has been designed and tested for the products listed in this document.

For more information, or if you are not sure if your TeamMate product is compatible please refer to an approved TeamMate reseller or distributor.

Required Tools

- 2.5mm Hex Wrench Allen Key
- 3mm Hex Wrench Allen Key
- 5mm Hex Wrench Allen Key
- Medium cross head screw driver
- 8mm Combination Wrench
- 19mm Socket Wrench

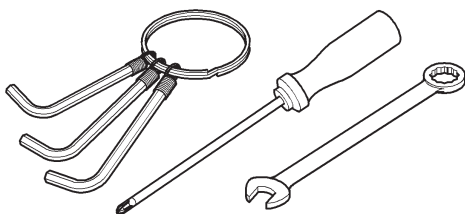

Safety warnings

Electrical

Observe all electrical and warning stickers

- To reduce the risk of fire or electric shock, do not expose any component of your TeamMate VariHite Mobile Stand to rain or moisture.

- Make sure that an electrical socket is near your TeamMate VariHite Mobile Stand for SMART Board product and remains easily accessible during use.
- All power must be disconnected before removing any covers on the TeamMate VariHite Mobile Stand.
- Exterior metal work is earth bonded.

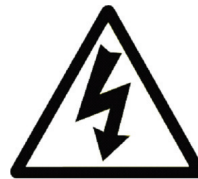

- Avoid damaging power cords or modifying power cord, power strip or any other internal wiring that has been supplied by Performance Enclosures.
- Do not attempt to service the TeamMate VariHite Mobile Stand other than performing routine safety checks; there are no user-serviceable parts inside the unit. Do not open or disassemble the TeamMate VariHite Mobile Stand as this may cause electric shock.
- If any component appears to be loose or becomes detached from the TeamMate VariHite Stand, Call an authorised TeamMate reseller for instructions. Do not attempt to repair the stand.
- Do not open the TeamMate VariHite Mobile Stand rack or screen support enclosure without disconnecting the unit from the mains supply.
- Before moving the TeamMate VariHite Mobile Stand always disconnect from the mains supply and any other connections.
- Always check the power cable and socket attached to the TeamMate VariHite Mobile Stand for signs of damage or wear.
- Once the TeamMate VariHite Mobile Stand has been configured for use it is advised that the appliance as a whole is PAT tested with all third party equipment installed to ensure that the system as a whole is electrically safe for use.
- Ensure that none of the earth straps supplied with the TeamMate VariHite Mobile Stand are disconnected, as this will compromise the route to earth during any potential shorting and may result in electrical shock. It is also advised that the earth strap to the selected projector mount is connected before use (Please refer to User Guide).
- At no time should the power bar inside the rack unit be tampered with or opened as this may result in electrical shock when connected to the mains supply.
- Regularly check that no mains cables are caught or snagged, as this may result in electric shock.

SMART Board VariHite

Cautions



Observe all Caution stickers

- Two people are required to safely mount your SMART Board on a TeamMate VariHite Mobile Stand; it might be too heavy for one person to safely manoeuvre alone. When you lift your SMART Board, you and your assistant should stand on either side of the screen, supporting its weight at the bottom corners while stabilising the top with your other hands. The wheels should be in the locked position to prevent the stand from moving.
- Do not leave cables on the floor where they can be a tripping hazard. If you must run a cable over the floor, lay it in a flat, straight line and secure it to the floor with tape or a cable management strip of a contrasting colour. Handle cables carefully and avoid excessive bending.
- Only mount products that are listed in this document. The TeamMate VariHite Mobile Stand is certified for use with the specified models.
- When the TeamMate is in position, lock down all castors. Failure to comply with this warning may result in instability leading to equipment damage or personal injury.
- Do not move the TeamMate VariHite Mobile Stand unless it's in the transport position. The TeamMate VariHite Stand must be lowered to the lowest position. The projector boom/mount must be in the transport position (please observe User Guide for correct position). Make sure clamping handle is tightened.
- Do not attempt to lift the TeamMate VariHite Mobile Stand unit when fully assembled.
- When moving the TeamMate VariHite Mobile Stand, please ensure that you have sufficient man power (please refer to your own health and safety policy).
- Ensure body parts, loose garments and any other items are kept away from all moving parts.
- The up and down control should only be activated using the supplied control switch, unless authorised by Performance Enclosures.
- Do not climb (or allow children to climb) on any part of your TeamMate VariHite Mobile Stand. Climbing on the whiteboard or projector boom could result in personal injury or product damage. Do not climb on, hang from, or suspend objects from any part of the projector system.
- Failure to follow the instructions shipped with your TeamMate VariHite Mobile Stand product could result in personal injury and damage to the product.
- When installing your SMART product to the TeamMate VariHite Mobile Stand for SMART Board, please refer to the relevant installation safety information provided with your SMART product.
- When mounting the projector on the TeamMate VariHite Stand, you must attach both the mounting bracket and safety tether to the provided stud to safely support the projector's weight. If the projector plate bolts come loose the projector may fall, resulting in product damage and possible personal injury.
- Ensure that any cables extending across the floor to your TeamMate VariHite Mobile Stand are properly bundled and marked to prevent a trip hazard.
- When lowering the screen support structure, ensure there are no objects overhanging the front face of the rack enclosure, as these may become entangled or crushed by the white board lower mounting plate. As a matter of precaution and to remind the user of this potential hazard, the screen will stop at 10cm from the potential crush point. The user will then have to release the down button on the control panel then re-apply pressure to the down button.
- When moving the TeamMate VariHite Mobile Stand, please ensure that the projector is moved in to its "Parked" position and locked off. Drop the height of the TeamMate VariHite Mobile Stand to its lowest position. It is recommended that, if using the swing projector option, that you move the projector head to the opposite side to the elevation control panel. At all times during elevation and lowering operations, check that the projector does not hit or clash with any surrounding object or person. It is advised that the use of the variable height operation is carried out by an adult who has been instructed in its use and has read this document.
- When moving the TeamMate VariHite Mobile Stand, ensure this operation is carried out by two adults each holding firmly the handles provided, always move the TeamMate VariHite Stand in the longitudinal direction (this means to the left or right when looking at the front surface of the stand with the board attached).
- Do not move the TeamMate VariHite Mobile Stand at any speed higher than a slow walk; failure to do so may result in the stand tipping, possibly causing injury, if it were to suddenly stop.
- Never move the TeamMate VariHite Mobile Stand with the projector in its fully extended vertical position, as this will damage or cause a tipping action that may result in injury or damage to the equipment.
- When moving up or down an incline ensure two adults are holding the TeamMate VariHite Mobile Stand handles to reduce the likelihood of toppling. Do not exceed the maximum incline angle of 5 degrees.
- It is recommended that the TeamMate VariHite Mobile Stand is moved over smooth surfaces, users need to be aware that rough surfaces, door thresholds and obstructions may induce a tipping action that may result in damage or injury.

SMART Board VariHite

Observe all Caution stickers

- Two people are required to safely mount your SMART Board on a TeamMate VariHite Mobile Stand; it might be too heavy for one person to safely manoeuvre alone. When you lift your SMART Board, you and your assistant should stand on either side of the screen, supporting its weight at the bottom corners while stabilising the top with your other hands. The wheels should be in the locked position to prevent the stand from moving.
- Do not leave cables on the floor where they can be a tripping hazard. If you must run a cable over the floor, lay it in a flat, straight line and secure it to the floor with tape or a cable management strip of a contrasting colour. Handle cables carefully and avoid excessive bending.
- Do not mount products not listed in this document. The TeamMate VariHite Mobile Stand is certified for use with the specified models.
- When the TeamMate is in position, lock down all castors. Failure to comply with this warning may result in instability leading to equipment damage or personal injury.
- Do not move the TeamMate VariHite Mobile Stand unless it's in the transport position. The TeamMate VariHite Stand must be lowered to the lowest position. The projector boom/mount must be in the transport position (please observe User Guide for correct position). Make sure clamping handle is tightened.
- Do not attempt to lift the TeamMate VariHite Mobile Stand unit when fully assembled.
- When moving the TeamMate VariHite Mobile Stand, please ensure that you have sufficient man power (please refer to your

Important information

- own health and safety policy).
- Ensure body parts, loose garments and any other items are kept away from all moving parts.
- The up and down control should only be activated using the supplied control switch, unless authorised by Performance Enclosures.
- Do not climb (or allow children to climb) on any part of your TeamMate VariHite Mobile Stand. Climbing on the whiteboard or projector boom could result in personal injury or product damage. Do not climb on, hang from, or suspend objects from any part of the projector system.
- Failure to follow the instructions shipped with your TeamMate VariHite Mobile Stand product could result in personal injury and damage to the product.
- When installing your SMART product to the TeamMate VariHite Mobile Stand for SMART Board, please refer to the relevant installation safety information provided with your SMART product.
- When mounting the projector on the TeamMate VariHite Stand, you must attach both the mounting bracket and safety tether to the provided stud to safely support the projector's weight. If the projector plate bolts come loose the projector may fall, resulting in product damage and possible personal injury.
- Ensure that any cables extending across the floor to your TeamMate VariHite Mobile Stand are properly bundled and marked to prevent a trip hazard.
- When lowering the screen support structure, ensure there are no objects overhanging the front face of the rack enclosure, as

SMART Board VariHite

- 1** Move boxed TeamMate unit onto a clean, level and dry assembly floor using forklift or pallet trolley
- Then remove strapping, top cap and sleeve to reveal pallet and tray

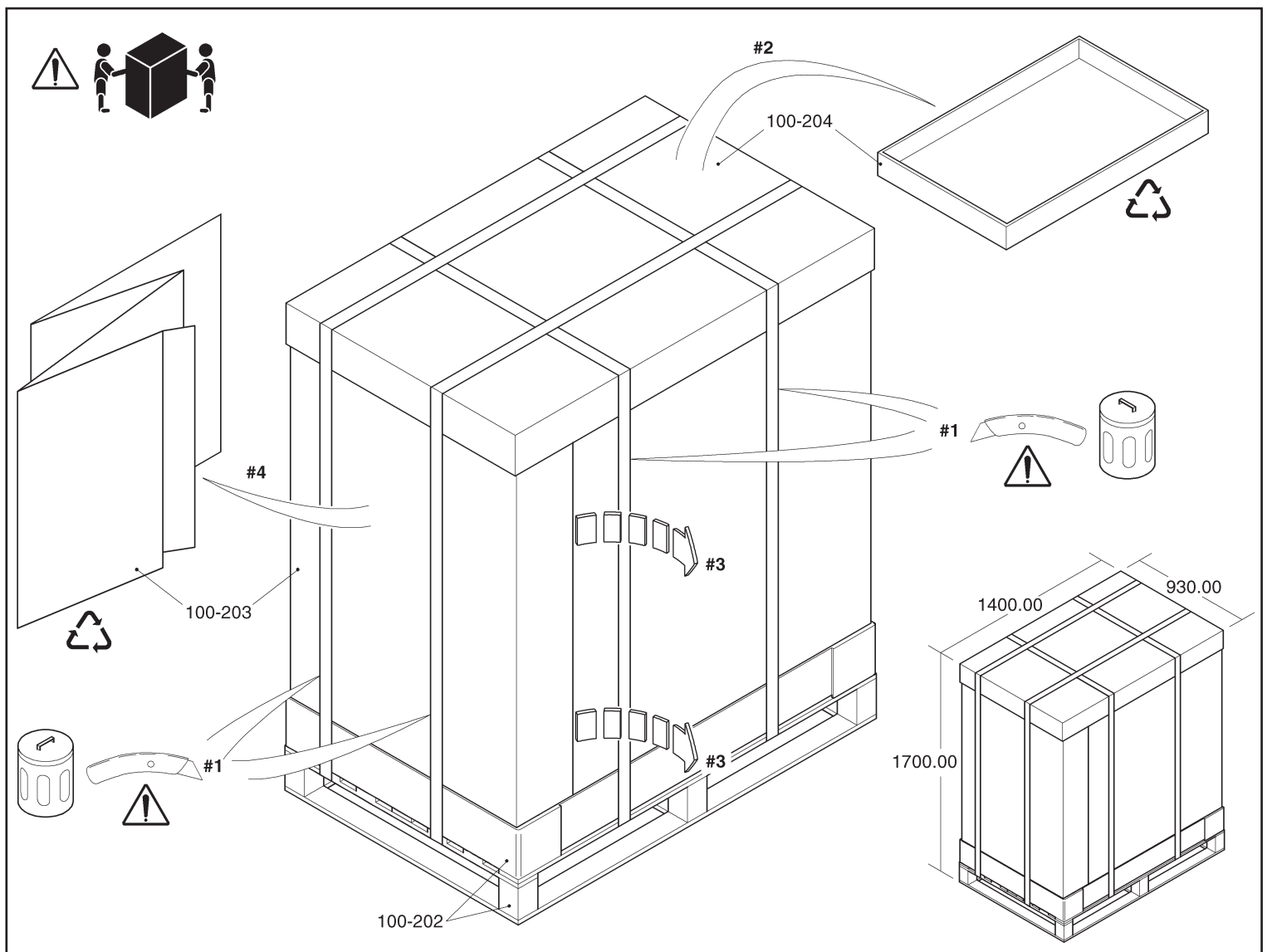

100-202	Custom designed pallet, tray and spacers for shipping bolts
100-203	One sleeve and Velcro closure
100-204	Top cap for pallet sleeve

SMART Board VariHite

2 TeamMate can now be removed from pallet or retained on pallet during integration, if preferred



Note:

Examine TeamMate in detail and report any damage immediately to manufacturer

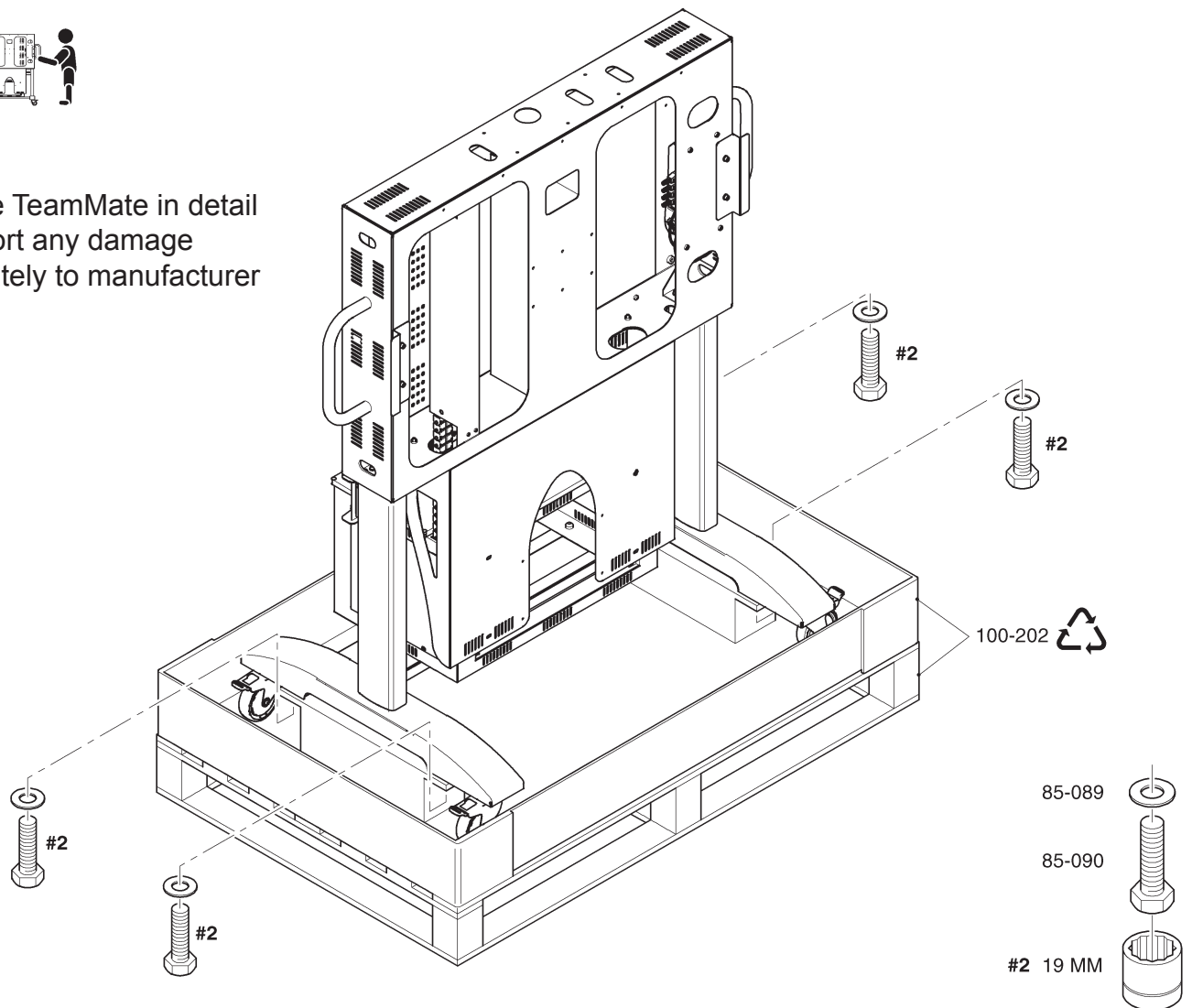

85-089	M12 plain washer form 'C' 28mm outside diameter
85-090	M12 x 40 hex head set screw

SMART Board VariHite

- 3** Remove frame rear cover, rack side panels and 2 x U rack blanks as necessary for integration
- Connect mains lead and test 'raise' 'lower' elevation control on display frame

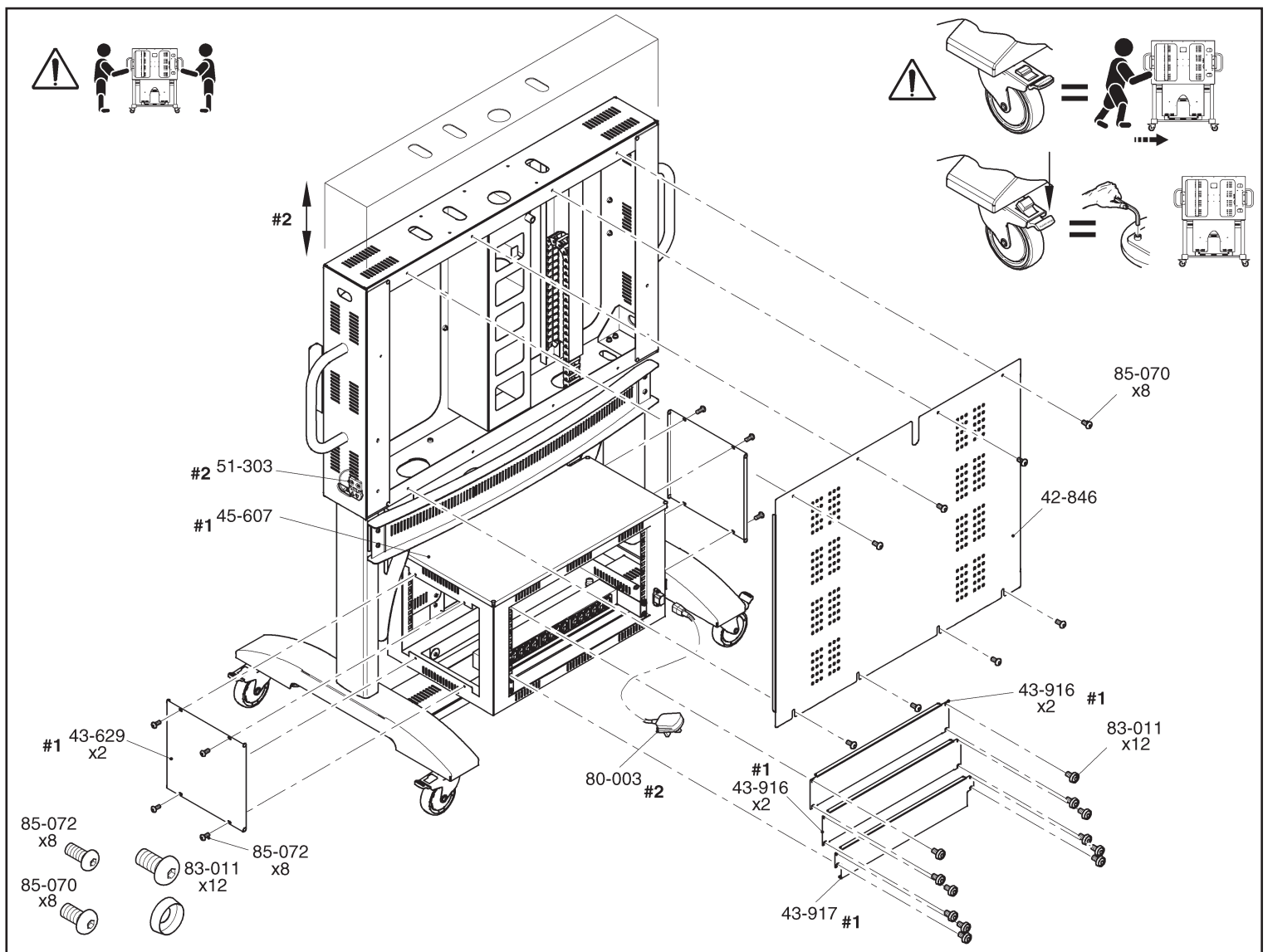

42-846	Display frame rear pepperpot cover	80-003	3 metre IEC plug socket cable
85-070	M5 x 10 stainless steel hex button head screw	43-916	2 U front and rear blanking plate
51-303	TeamMate VariHite elevation control - Linak	43-917	2 U PSU cover
45-607	Rack desk top	85-072	M4 x 12 stainless hex button head screw
43-629	6 U rack side covers	83-011	M6 cage nut assembly

SMART Board VariHite



Advisory Notes: TeamMate VariHite Stand electrical circuit layout before integration

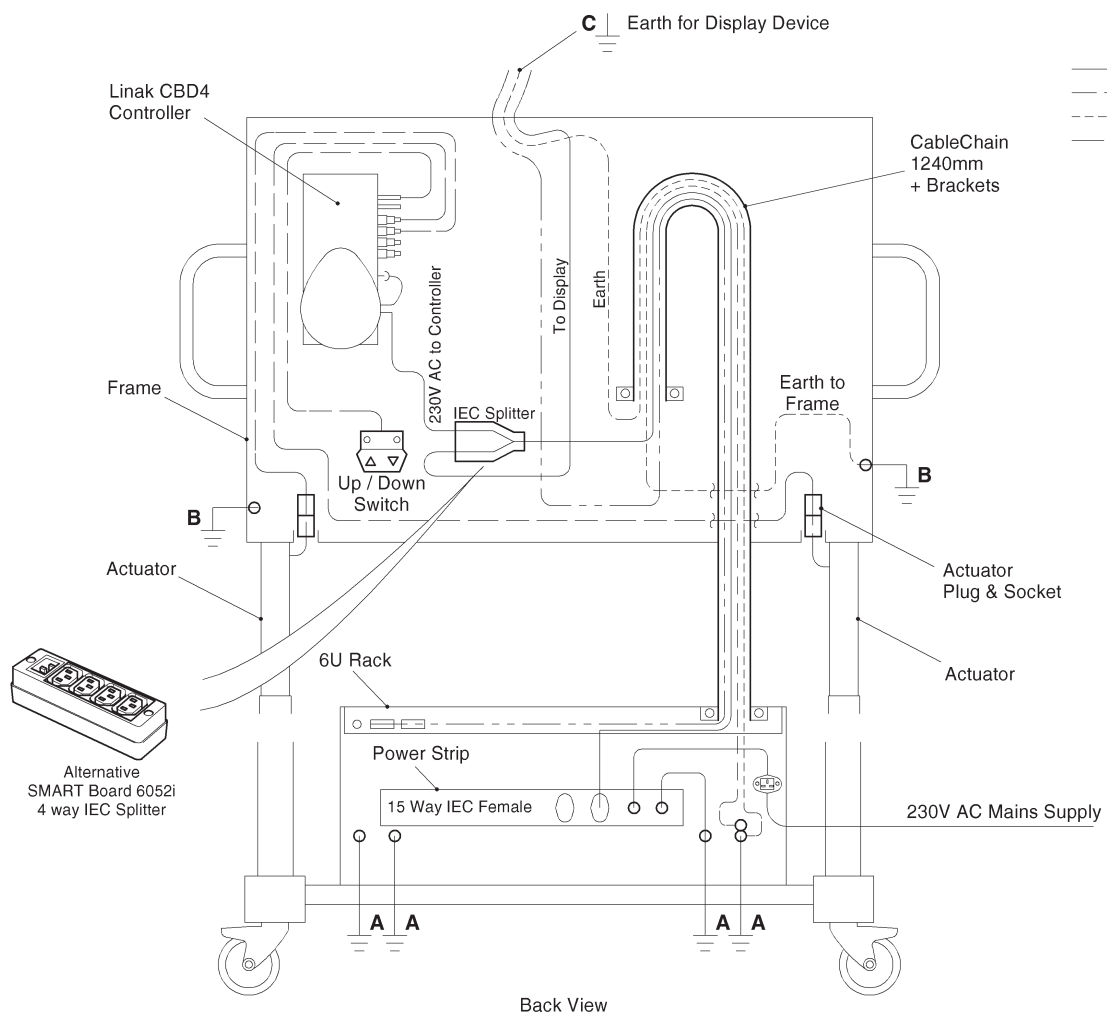

SMART Board VariHite



Advisory Notes: Integrating TeamMate VariHite, cable chain, cable management and testing

Note: Ensure that no earth straps are removed. We recommend that a PAT test is carried out after final integration to ensure safe and sufficient earth bonding. If you require a patch panel for the rear of the rack you can use any industry standard blanking panel with your desired cut outs for connections to external and internal devices.

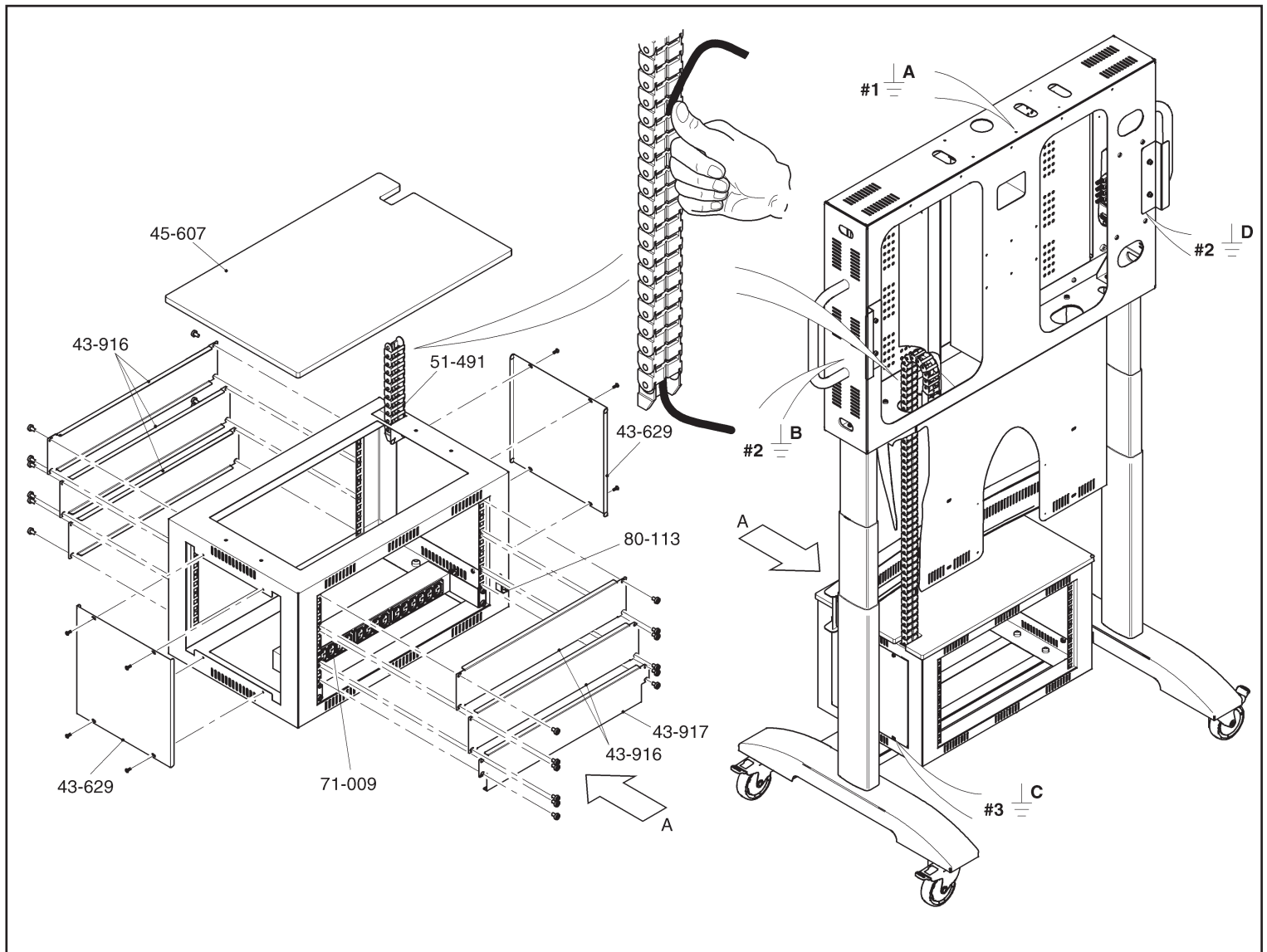

43-917	2U PSU cover	43-916	2U rear blanking plates
43-916	2U front blanking plates	43-629	Rack side inspection covers
46-607	Rack work top	80-113	IEC power input
51-491	Cable chain	71-009	Mains distribution power supply

Note: Ensure cable chain (51-491) is not overpacked with cable as this may cause damage to the chain mechanism. Make sure the links are connected and seated correctly and not buckled.

SMART Board VariHite

Waste Electrical and Electronic Equipment Regulations

This document contains information about your TeamMate product and the Waste Electrical and Electronic Equipment (WEEE) regulations that apply to all electrical and electronic equipment within the European Union.

When you dispose of any electrical or electronic equipment, including TeamMate products, we strongly encourage you to contact your local WEEE recycling agency for recycling and disposal advice.

Your TeamMate product required the extraction and use of natural resources for its production. It may contain hazardous substances. By disposing of electrical and electronic equipment appropriately, you lower the impact of these substances upon health and the environment and reduce the pressure on natural resources. Recycling agencies can reuse or recycle most of the materials from your product.

Please think about how you intend to dispose of any product that has a WEEE symbol or accompanying WEEE guidelines.

If you need more information on the collection, re-use and recycling of electrical and electronic equipment, please contact your local WEEE recycling agency.

Alternatively, contact your local reseller or Performance Enclosures for information on the environmental performance of our products.



Customer Support

Online Information and Support

Visit www.teammate.co.uk to view and download user's guides.

Technical Support

If you experience difficulty with your TeamMate product, please contact your local reseller before contacting TeamMate Technical Support. Your local reseller can resolve most issues without delay.

NOTE

To locate your local reseller, visit www.teammate.co.uk or email us at info@teammate.co.uk

Tel: (00)44 (0)1491 825739
(9am to 5.30pm Monday to Friday Europe)
Fax: (00)44 (0)1491 838568
Email: info@teammate.co.uk
Website: www.teammate.co.uk

Shipping and Repair Status

Contact Performance Enclosures Return of Merchandise Authorisation (RMA) team, on +44 (0)1491 825739, for shipping damage, missing part and repair status issues.

General Enquiries

Address: 6 Rockfort Industrial Estate, Hithercroft Road, Wallingford, Oxfordshire, OX10 9DA, United Kingdom.

Tel: (00)44 (0)1491 825739
(9am to 5.30pm Monday to Friday Europe)
Fax: (00)44 (0)1491 838568
Email: info@teammate.co.uk
Website: www.teammate.co.uk

Warranty

Product warranty is governed by the terms and conditions of Performance Enclosures "Limited Equipment Warranty" that shipped with the TeamMate product at the time of purchase.

Registration

To help us serve you, register by filling in your registration card and returning it to Performance Enclosures Limited.

SMART Board VariHite

Limited Equipment Warranty

Thank you for your recent purchase. In the unlikely event that you have problems with your TeamMate equipment, TeamMate technical support is available to assist. The terms of your TeamMate Warranty are as follows below; please read carefully all sections of this document and the relevant procedures.

For clarity **TeamMate** is the registered trade name for **products** Manufactured by Performance Enclosures Limited (the legal entity)

Limited warranty provided to end user purchaser

Subject to the exceptions noted below, this is a limited warranty (the "Warranty") and covers all defects in materials and workmanship of your TeamMate product (the "Equipment"). Performance Enclosures the manufacturer of TeamMate equipment extends the warranty to the end user (the "Purchaser") of the equipment.

The duration of the warranty (the "Warranty Period"), commencing on the date of purchase, is **5 years** for the Equipment metal frame support. The electrically powered actuators, associated controller, power bars and cables are covered by a warranty of **3 years**.

The Warranty is in Lieu of all other warranties, whether expressed, implied or statutory, including but not limited to implied Warranties of merchantability and fitness for a particular purpose. Any representation or Warranty, or affirmation of fact, made by any sales representative or other agent of Performance Enclosures Limited, including but not limited to statements regarding capacity, suitability for use or performance, express or implied, which is not specifically set forth herein will not be binding upon Performance Enclosures Limited.

Performance Enclosures Limited has not authorised any other party except the distributor to alter, modify, extend, enhance or limit the Warranty and Performance Enclosures will not assume any responsibility or liability for any statements or representations made by persons or entities.

Replace or Repair

The Purchaser's exclusive remedy and Performance Enclosures sole obligation during the warranty period shall be for Performance Enclosures to repair or, at its option replace the Equipment that has failed or that has proven to be defective at no cost to the Purchaser except for the one way shipping cost of the equipment to a TeamMate product authorised service centre. Any charges associated with a rush order request such as air express or same day courier, are the responsibility of the Purchaser.

Prior to returning any equipment under warranty, the purchaser must render proof of the original purchase date and must thereafter obtain from Performance Enclosures a Return of Merchandise Authorisation (RMA) number.

The RMA number shall be clearly marked on the packaging of the Equipment being returned. All equipment that is replaced under warranty shall become the property of Performance Enclosures.

Limitation of Damages

The liability of Performance Enclosures Limited to the Purchaser arising out of the purchase and supply of the Equipment or its use, whether based upon Warranty, contract, tort (including, without limitation, negligence) or otherwise, shall not in any case exceed the original cost to the Purchaser of the Equipment, and upon expiration of the warranty period such liability will terminate.

Performance Enclosures shall not be liable, whether in contract or on any other basis, for any damages sustained by the Purchaser or any other person arising from or related to loss of use, failure or interruption in the operation of the Equipment, delay in repair or replacement or incidental, inconsequential, indirect or special damages or liabilities, loss of revenue, loss of business or financial loss arising out of or in connection with the sale, lease, maintenance, use, hire, performance failure or interruption of the equipment.

Warranty Exclusions

The Warranty will not apply to and Performance Enclosures will not be liable for:

1. Any Equipment, which is not purchased from an authorised TeamMate Dealer or distributor.
2. Equipment that has been damaged by accident, abuse, neglect, misuse or causes other than ordinary use (see manuals that ship with Equipment for further detail), including the direct application of any cleaning liquids, substances or abrasives to the hardware, other than in accordance with the **User Manual**.
3. Equipment that has been altered, changed, serviced or repaired by anyone other than an authorised TeamMate repair centre.
4. Any Equipment, on which the serial number has been defaced, modified or removed. Warranty service hereunder shall not operate to extend the original Warranty period. The warranty excludes damage incurred in shipment to or from Performance Enclosures or its authorised representatives. If the Equipment is received by the Purchaser in a damaged condition, the carrier, dealer/distributor and Performance Enclosures must be notified immediately. Purchasers located outside the UK should contact their TeamMate dealer or distributor.

Third Party Equipment Warranty extension and exception

For equipment sold by Performance Enclosures to the Purchaser but manufactured by a Corporation other than Performance Enclosures (such as Linak Elevators and associated accessories) Performance Enclosures shall extend to the Purchaser, to the extent permitted, any and all applicable warranty provisions provided to Performance Enclosures by the third party manufacturer. The extension of any and all applicable third party manufacturer warranty provisions shall be the exception to this Warranty and represents Performance Enclosures sole responsibility with respect to such warranty.

Tel: +44 (0) 1491 825739

Fax: +44 (0) 1491 838568

Email: info@teammate.co.uk Visit: www.teammate.co.uk

**Manufactured in the UK by: Performance Enclosures Limited,
6 Rockfort, Hithercroft Road, Wallingford, Oxon, OX10 9DA, United Kingdom**

Warranty Claim Procedures

Performance Enclosures technical support can help you make a warranty claim, Please call us on:

Tel: (00)44 (0)1491 825739
(9am to 5.30pm Monday to Friday Europe)
Fax: (00)44 (0)1491 838568
Email: info@teammate.co.uk
Website: www.teammate.co.uk

If you are located outside Europe you may want to contact your TeamMate dealer to make a warranty claim.

Hardware Failure or defects out of the packaging

Should equipment fail to function when installed within 15 days of the date of purchase, Performance Enclosures Limited or the authorised distributor will handle the problem by first attempting to understand and correct the problem via the telephone.

If TeamMate's technical support personnel or the distributors technical help line are unable to correct the situation, an RMA number will be promptly issued authorising the return of the hardware to a TeamMate authorised service centre. The RMA charges associated with a rush-request order, such as air express or same day courier, are the responsibility of the Purchaser.

Replacement components, subject to availability, will be shipped to the purchaser's site within two business day as the technical support call is received or on the next business day via pre-paid ground transport. The freight charges for the return shipment via ground transportation will be the responsibility of the distributor. Any charges associated with the rush-request order, such as air express, are the responsibility of the Purchaser.

Damages caused by transportation are not covered by the warranty

If the hardware failure is caused by freight damage, it is the Purchaser's responsibility to note the packaging damaged condition; the carrier and TeamMate must be notified within 30 days of the delivery date.

Equipment Failure or defects within the warranty period

Performance Enclosures will handle the problem by first attempting to understand and correct the problem via telephone support. If Performance Enclosures' technical support team are unable to correct the problem, an RMA shipping number will be promptly issued, authorising the return of the equipment to a TeamMate Authorised service centre. The RMA shipping charges will be the responsibility of the Purchaser.

Upon receipt of the returned component, Performance Enclosures will establish the cause of the problem. At the sole discretion of Performance Enclosures, the failed or defective equipment will be either repaired or replaced in accordance with Performance Enclosures Warranty. The return shipment will be made, usually within the next 3 business days after the defective RMA equipment is received. The shipping charges for the return shipment via ground transportation will be the responsibility of Performance Enclosures. Any charges associated with a rush requested order such as airfreight are the responsibility of the Purchaser.

Warranty shipping charges

Unless there is a hardware failure or defect out of the packaging or unless specifically agreed by Performance Enclosures, shipping charges incurred for warranty services are paid as follows:

The purchaser shall return the goods covered by the RMA via pre-paid freight to a TeamMate authorised service centre. The distributor pays the return shipping via the most economical service on any failed or defective product returned for service within the warranty period. Any charges associated with a rush-request order such as air express, are the responsibility of the Purchaser.

Following the warranty period, the Purchaser is responsible for the equipment to and from the Performance Enclosures authorised service centre.

Dealer/distributor support and service

Additional service and support contracts may be available from your authorised TeamMate product dealer or distributor. Cost may vary with service and support requested.

Trademark Notice

SMART Board, The SMART logo, GoWire and smarttech are trademarks or registered trademarks of SMART Technologies ULC in the U.S. and/or other countries. EXPO and Sanford are registered U.S. trademarks of SANFORD or its affiliates. VESA is a registered trademark of The Video Electronics Standards Association. Windows is either a registered trademark or a trademark of Microsoft Corporation in the U.S. and/or other countries. TeamMate is a registered Trademark of Performance Enclosures Limited in the UK. All other third-party product and company names may be trademarks of their respective owners.

Copyright Notice

©2010 Performance Enclosures Limited. All rights reserved. No part of this publication may be reproduced, transmitted, transcribed, stored in a retrieval system or translated into any language in any form by any means without the prior written consent of Performance Enclosures Limited. Information in this manual is subject to change without notice and does not represent a commitment on the part of Performance Enclosures Limited. Patents Pending and Patented UK & Foreign. TeamMate is a registered trademark of Performance Enclosures Limited.

While Performance Enclosures Limited makes every effort to provide accurate and complete information on the installation of its products, it will not be held liable for any editorial errors or emissions (including those made in the process of translation from English to another language, or for incidental, special or consequential damages of any nature resulting from furnishing this instruction and performance of the equipment in connection with this instruction. Performance Enclosures Limited reserves the right to make changes in the product design and/or product document without notification to its users. For the most current product information, or to know if this document is available in languages other than those herein, please contact Performance enclosures.

Patents Pending and Patented UK & Foreign.